

道路横断用側溝 (ボルト固定式)

製品名称：TFC-UFG

- 水路幅員・水路深さが自在なため広い範囲の断面を自在に選定いただけます。
- 側溝本体及びグレーチングはT-25仕様です。
- グレーチング及びアングルはノンスリップ仕様です。



設計条件

① 活荷重

T-25 片側後輪一輪荷重 $Q = 50\text{kN}$ (5tf)
 衝撃係数 $i = 0.3$

T-25 片側後輪一輪

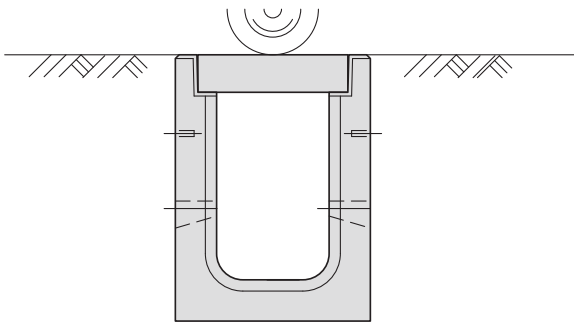

② 土質条件、その他

- ・ 土の単位体積重量 $\gamma_d = 19\text{kN/m}^3$
- ・ 土の内部摩擦角 $\phi = 30^\circ$
- ・ 土とコンクリートの摩擦角 $\delta = 20^\circ$
- ・ 鉄筋コンクリートの単位体積重量 $\gamma_c = 24.5\text{kN/m}^3$
- ・ 土圧計算は、試行くさび法による。

③ 許容応力度

- ・ コンクリート
 - 設計基準強度 $\sigma_{ck} = 30\text{N/mm}^2$
 - 許容曲げ圧縮応力度 $\sigma_{ca} = 11\text{N/mm}^2$
 - 許容せん断応力度 $\tau_{ca} = 0.5\text{N/mm}^2$
- ・ 鉄筋
 - 許容引張応力度 (SR235) $\sigma_{sa} = 137\text{N/mm}^2$
 - 許容引張応力度 (SD295) $\sigma_{sa} = 176\text{N/mm}^2$
 - 許容引張応力度 (SD345) $\sigma_{sa} = 196\text{N/mm}^2$

※上記設計条件以外は別途ご相談ください。

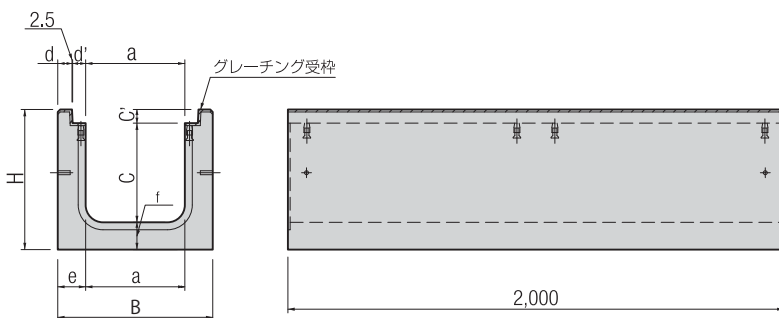

TFC-UFG用グレーチング

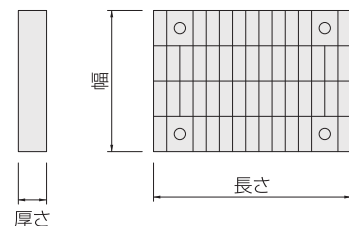

形状寸法及び製品質量

呼び名	形状寸法(mm)								製品質量 (kg/本)	グレーチング寸法(mm) 幅×長さ×厚さ	グレーチング質量 (kg/枚)	
	a	c	c'	d	d'	e	f	B				H
30×34.5 UFG	300	345	55	80	52.5	135	135	570	535	903	400×995×55	29.7
30×44.5 UFG		445							635	1,038		
30×54.5 UFG		545							735	1,173		
30×64.5 UFG		645							835	1,307		
30×74.5 UFG		745							935	1,443		
30×84.5 UFG		845							1,035	1,578		
30×94.5 UFG		945							1,135	1,713		
30×104.5 UFG		1,045							1,235	1,847		
30×114.5 UFG		1,145							1,335	1,982		
30×124.5 UFG		1,245							1,435	2,117		
40×34.5 UFG		400							345	65		
40×44.5 UFG	445		645	1,114								
40×54.5 UFG	545		745	1,249								
40×64.5 UFG	645		845	1,383								
40×74.5 UFG	745		945	1,518								
40×84.5 UFG	845		1,045	1,653								
40×94.5 UFG	945		1,145	1,788								
40×104.5 UFG	1,045		1,245	1,922								
40×114.5 UFG	1,145		1,345	2,057								
40×124.5 UFG	1,245		1,445	2,193								
45×34.5 UFG	450		345	75	80	52.5	135	135	720		555	1,021
45×44.5 UFG		445	655							1,155		
45×49.5 UFG		495	705							1,223		
45×54.5 UFG		545	755							1,290		
45×64.5 UFG		645	855							1,426		
45×74.5 UFG		745	955							1,561		
45×84.5 UFG		845	1,055							1,695		
45×94.5 UFG		945	1,155							1,830		
45×104.5 UFG		1,045	1,255							1,965		
45×114.5 UFG		1,145	1,355							2,099		
45×124.5 UFG		1,245	1,455							2,234		
50×34.5 UFG	500	345	75	80	52.5	135	135	770	555	1,054	600×995×75	59.0
50×44.5 UFG		445							655	1,189		
50×54.5 UFG		545							755	1,324		
50×64.5 UFG		645							855	1,459		
50×74.5 UFG		745							955	1,594		
50×84.5 UFG		845							1,055	1,729		
50×94.5 UFG		945							1,155	1,864		
50×104.5 UFG		1,045							1,255	1,998		
50×114.5 UFG		1,145							1,355	2,133		
50×124.5 UFG		1,245							1,455	2,268		
60×33 UFG		600							330	90		
60×43 UFG	430		655	1,260								
60×53 UFG	530		755	1,395								
60×63 UFG	630		855	1,530								
60×73 UFG	730		955	1,664								
60×83 UFG	830		1,055	1,799								
60×93 UFG	930		1,155	1,934								
60×103 UFG	1,030		1,255	2,068								
60×113 UFG	1,130		1,355	2,203								
60×123 UFG	1,230		1,455	2,338								
70×30 UFG	700		300	130	62.5	70	135	135	970		565	1,162
70×40 UFG		400	665							1,297		
70×50 UFG		500	765							1,431		
70×60 UFG		600	865							1,566		
70×70 UFG		700	965							1,701		
70×80 UFG		800	1,065							1,836		
70×90 UFG		900	1,165							1,970		
70×100 UFG		1,000	1,265							2,105		
70×110 UFG		1,100	1,365							2,240		
70×120 UFG		1,200	1,465							2,374		
80×30 UFG		800	300							130	62.5	70
80×40 UFG	400		665	1,364								
80×50 UFG	500		765	1,499								
80×60 UFG	600		865	1,633								
80×70 UFG	700		965	1,768								
80×80 UFG	800		1,065	1,903								
80×90 UFG	900		1,165	2,038								
80×100 UFG	1,000		1,265	2,172								
80×110 UFG	1,100		1,365	2,307								
80×120 UFG	1,200		1,465	2,443								
90×30 UFG	900		300	160	62.5	80	145	145	1,190			
90×40 UFG		400	705							1,564		
90×50 UFG		500	805							1,709		
90×60 UFG		600	905							1,853		
90×70 UFG		700	1,005							1,998		
90×80 UFG		800	1,105							2,143		
90×90 UFG		900	1,205							2,287		
90×100 UFG		1,000	1,305							2,432		
90×110 UFG		1,100	1,405							2,577		
90×120 UFG		1,200	1,505							2,722		
100×30 UFG		1,000	300							160	62.5	80
100×40 UFG	400		705	1,636								
100×50 UFG	500		805	1,781								
100×60 UFG	600		905	1,926								
100×70 UFG	700		1,005	2,070								
100×80 UFG	800		1,105	2,215								
100×90 UFG	900		1,205	2,360								
100×100 UFG	1,000		1,305	2,504								
100×110 UFG	1,100		1,405	2,649								
100×120 UFG	1,200		1,505	2,795								