

2・4分割大型ボックスカルバート

製品名称：KCV



設計条件

①活荷重

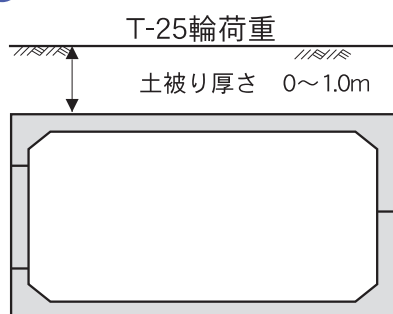

※T-25輪荷重で横断設計しています。

②土質条件その他

- ・アスファルト舗装： $\gamma_a = 22.5 \text{ kN/m}^3$
- ・鉄筋コンクリート： $\gamma_c = 24.5 \text{ kN/m}^3$
- ・土： $\gamma_d = 18.0 \text{ kN/m}^3$

④その他

- 土圧係数： $K_0 = 0.5$
- ヤング係数比： $n = 15$

③許容応力度

- ・コンクリート
 - 設計基準強度： $\sigma_{ck} = 50 \text{ N/mm}^2$
 - 許容曲げ圧縮応力度： $\sigma_{ca} = 16.0 \text{ N/mm}^2$
 - 許容せん断応力度： $\tau_{ca} = 0.27 \text{ N/mm}^2$ (補正前)
 - 許容付着力度： $\tau_{0a} = 2.0 \text{ N/mm}^2$
- ・鉄筋 (SD295A, SD345)
 - 許容引張応力度： $\sigma_{sa} = 160 \text{ N/mm}^2$
- ・KTジョイント
 - アンカー鉄筋の許容引張応力度 (SD345)
 - 全タイプ： $\sigma_{sa} = 160 \text{ N/mm}^2$
 - ボルト許容引張応力度
 - D25タイプ： $\sigma_{ba} = 480 \text{ N/mm}^2$
 - D32・38タイプ： $\sigma_{ba} = 160 \text{ N/mm}^2$
 - ボルト許容せん断応力度
 - D25タイプ： $\tau_{ba} = 270 \text{ N/mm}^2$
 - D32・38タイプ： $\tau_{ba} = 80 \text{ N/mm}^2$
 - カブラーの許容引張応力度 (FCD600-3)
 - 全タイプ： $\sigma_{ka} = 200 \text{ N/mm}^2$
 - カブラーの許容せん断応力度 (FCD600-3)
 - 全タイプ： $\tau_{ka} = 110 \text{ N/mm}^2$

⑤準用示方書等

- (社) 日本道路協会 道路土工・カルバート工指針
- (財) 国土開発技術研究センター
 - 鉄筋コンクリート製プレキャスト
 - ボックスカルバート道路埋設指針
- (社) 土木学会 コンクリート標準示方書
- (社) 日本道路協会 道路橋示方書・解説 鋼橋編

上記設計条件以外は別途ご相談ください

形状寸法及び製品質量

製品サイズ	内幅 b (mm)	内高 h (mm)	全幅 B (mm)	全高 H (mm)	頂版厚 t1 (mm)	底版厚 t2 (mm)	側壁厚 t3 (mm)	接続位置 h1 (mm)	製品長 L (mm)	頂底版 (kg/本)	側版 (kg/本)	1組質量 (kg/本)
3,000	3,000	1,500	3,400	1,940	220	220	200	*	2,000	5,690	—	11,380
		1,600	3,400	2,040	220	220	200	*	2,000	5,790	—	11,580
		1,700	3,400	2,140	220	220	200	*	2,000	5,890	—	11,780
		1,800	3,400	2,240	220	220	200	*	2,000	5,990	—	11,980
		1,900	3,400	2,340	220	220	200	*	2,000	6,090	—	12,180
		2,000	3,400	2,440	220	220	200	*	2,000	6,190	—	12,380
		2,100	3,400	2,540	220	220	200	*	2,000	6,290	—	12,580
		2,200	3,400	2,640	220	220	200	*	2,000	6,390	—	12,780
		2,300	3,400	2,740	220	220	200	*	2,000	6,490	—	12,980
		2,400	3,400	2,840	220	220	200	*	2,000	6,590	—	13,180
		2,500	3,400	2,940	220	220	200	*	2,000	6,690	—	13,380
		2,600	3,400	3,040	220	220	200	*	2,000	6,790	—	13,580
		2,700	3,400	3,140	220	220	200	*	2,000	6,890	—	13,780
		2,800	3,400	3,240	220	220	200	*	2,000	6,990	—	13,980
		2,900	3,400	3,340	220	220	200	*	2,000	7,090	—	14,180
3,000	3,400	3,440	220	220	200	*	2,000	7,190	—	14,380		

内幅 (b) 3,100～3,400までの製品も上記の寸法表の内高 (h) にて製造が可能です。

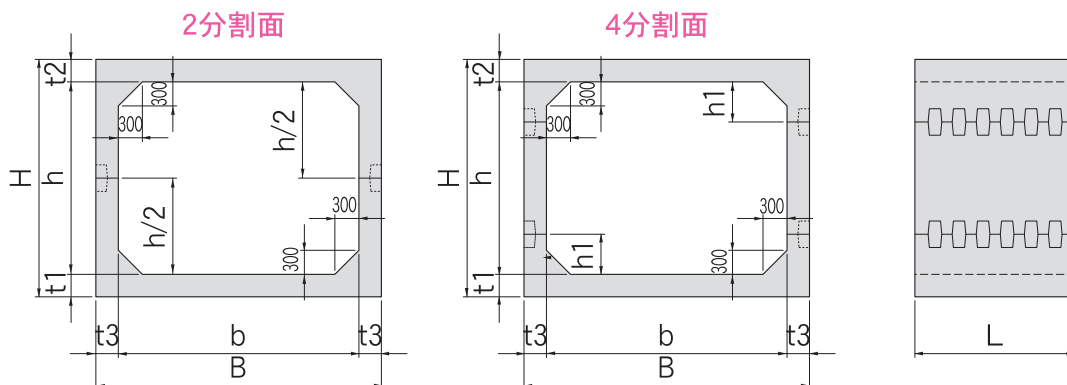

形状寸法及び製品質量

製品サイズ	内幅 b (mm)	内高 h (mm)	全幅 B (mm)	全高 H (mm)	頂版厚 t1 (mm)	底版厚 t2 (mm)	側壁厚 t3 (mm)	接続位置 h1 (mm)	製品長 L (mm)	頂底版 (kg/本)	側版 (kg/本)	1組質量 (kg/本)
3,500	3,500	1,500	3,900	1,980	240	240	200	*	2,000	6,630	—	13,260
		1,600	3,900	2,080	240	240	200	*	2,000	6,730	—	13,460
		1,700	3,900	2,180	240	240	200	*	2,000	6,830	—	13,660
		1,800	3,900	2,280	240	240	200	*	2,000	6,930	—	13,860
		1,900	3,900	2,380	240	240	200	*	2,000	7,030	—	14,060
		2,000	3,900	2,480	240	240	200	*	2,000	7,130	—	14,260
		2,100	3,900	2,580	240	240	200	*	2,000	7,230	—	14,460
		2,200	3,900	2,680	240	240	200	*	2,000	7,330	—	14,660
		2,300	3,900	2,780	240	240	200	*	2,000	7,430	—	14,860
		2,400	3,900	2,880	240	240	200	*	2,000	7,530	—	15,060
		2,500	3,900	2,980	240	240	200	*	2,000	7,630	—	15,260
		2,600	3,900	3,080	240	240	200	*	2,000	7,730	—	15,460
		2,700	3,900	3,180	240	240	200	*	2,000	7,830	—	15,660
		2,800	3,900	3,280	240	240	200	*	2,000	7,930	—	15,860
		2,900	3,900	3,380	240	240	200	*	2,000	8,030	—	16,060
		3,000	3,900	3,480	240	240	200	*	2,000	8,130	—	16,160
3,100	3,900	3,580	240	240	200	*	2,000	8,230	—	16,260		
3,200	3,900	3,680	240	240	200	*	2,000	8,330	—	16,460		
3,300	3,900	3,780	240	240	200	*	2,000	8,430	—	16,660		
3,400	3,900	3,880	240	240	200	*	2,000	8,530	—	17,060		
3,500	3,900	3,980	240	240	200	*	2,000	8,630	—	17,260		
内幅 (b) 3,600~3,900までの製品も上記の寸法表の内高 (h) にて製造が可能です。												
4,000	4,000	1,500	4,480	2,020	260	260	240	*	2,000	8,074	—	16,148
		1,600	4,480	2,120	260	260	240	*	2,000	8,194	—	16,388
		1,700	4,480	2,220	260	260	240	*	2,000	8,314	—	16,628
		1,800	4,480	2,320	260	260	240	*	2,000	8,434	—	16,868
		1,900	4,480	2,420	260	260	240	*	2,000	8,554	—	17,108
		2,000	4,480	2,520	260	260	240	*	2,000	8,674	—	17,348
		2,100	4,480	2,620	260	260	240	*	2,000	8,794	—	17,588
		2,200	4,480	2,720	260	260	240	*	2,000	8,914	—	17,828
		2,300	4,480	2,820	260	260	240	*	2,000	9,034	—	18,068
		2,400	4,480	2,920	260	260	240	*	2,000	9,154	—	18,308
		2,500	4,480	3,020	260	260	240	*	2,000	9,274	—	18,548
		2,600	4,480	3,120	260	260	240	*	2,000	9,394	—	18,788
		2,700	4,480	3,220	260	260	240	*	2,000	9,514	—	19,028
		2,800	4,480	3,320	260	260	240	*	2,000	9,634	—	19,268
		2,900	4,480	3,420	260	260	240	*	2,000	9,754	—	19,508
		3,000	4,480	3,520	260	260	240	*	2,000	9,874	—	19,748
		3,100	4,480	3,620	260	260	240	*	2,000	9,994	—	19,988
		3,200	4,480	3,720	260	260	240	*	2,000	10,114	—	20,228
		3,300	4,480	3,820	260	260	240	*	2,000	10,234	—	20,468
3,400	4,480	3,920	260	260	240	*	2,000	10,354	—	20,708		
3,500	4,480	4,020	260	260	240	*	2,000	10,474	—	20,948		
3,600	4,480	4,120	260	260	240	*	2,000	10,594	—	21,188		
3,700	4,480	4,220	260	260	240	*	2,000	10,714	—	21,428		
3,800	4,480	4,320	260	260	240	*	2,000	10,834	—	21,668		
3,900	4,480	4,420	260	260	240	*	2,000	10,954	—	21,908		
4,000	4,480	4,520	260	260	240	*	2,000	11,074	—	22,148		
内幅 (b) 4,100~4,400までの製品も上記の寸法表の内高 (h) にて製造が可能です。												
4,500	4,500	1,500	4,980	2,060	280	280	240	*	2,000	9,222	—	18,444
		1,600	4,980	2,160	280	280	240	*	2,000	9,342	—	18,684
		1,700	4,980	2,260	280	280	240	*	2,000	9,462	—	18,924
		1,800	4,980	2,360	280	280	240	*	2,000	9,582	—	19,164
		1,900	4,980	2,460	280	280	240	*	2,000	9,702	—	19,404
		2,000	4,980	2,560	280	280	240	*	2,000	9,822	—	19,644

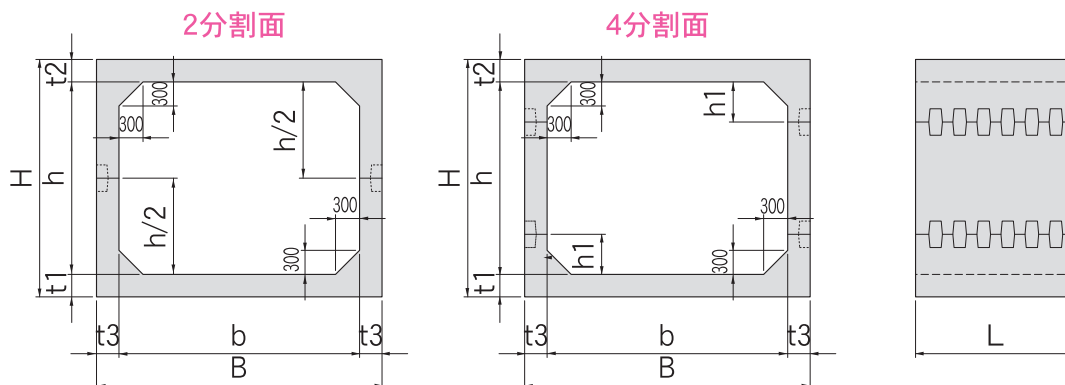

形状寸法及び製品質量

製品サイズ	内幅 b (mm)	内高 h (mm)	全幅 B (mm)	全高 H (mm)	頂版厚 t1 (mm)	底版厚 t2 (mm)	側壁厚 t3 (mm)	接続位置 h1 (mm)	製品長 L (mm)	頂底版 (kg/本)	側版 (kg/本)	1組質量 (kg/本)
4,500	4,500	2,100	4,980	2,660	280	280	240	*	2,000	9,942	—	19,884
		2,200	4,980	2,760	280	280	240	*	2,000	10,062	—	20,124
		2,300	4,980	2,860	280	280	240	*	2,000	10,182	—	20,364
		2,400	4,980	2,960	280	280	240	*	2,000	10,302	—	20,604
		2,500	4,980	3,060	280	280	240	*	2,000	10,422	—	20,844
		2,600	4,980	3,160	280	280	240	*	2,000	10,542	—	21,084
		2,700	4,980	3,260	280	280	240	*	2,000	10,662	—	21,324
		2,800	4,980	3,360	280	280	240	*	2,000	10,782	—	21,564
		2,900	4,980	3,460	280	280	240	*	2,000	10,902	—	21,804
		3,000	4,980	3,560	280	280	240	*	2,000	11,022	—	22,044
		3,100	4,980	3,660	280	280	240	*	2,000	11,142	—	22,284
		3,200	4,980	3,760	280	280	240	*	2,000	11,262	—	22,524
		3,300	4,980	3,860	280	280	240	*	2,000	11,382	—	22,764
		3,400	4,980	3,960	280	280	240	*	2,000	11,502	—	23,004
		3,500	4,980	4,060	280	280	240	*	2,000	11,622	—	23,244
		3,600	4,980	4,160	280	280	240	*	2,000	11,742	—	23,484
		3,700	4,980	4,260	280	280	240	*	2,000	11,862	—	23,724
		3,800	4,980	4,360	280	280	240	*	2,000	11,982	—	23,964
		3,900	4,980	4,460	280	280	240	*	2,000	12,102	—	24,204
		4,000	4,980	4,560	280	280	240	*	2,000	12,222	—	24,444
4,100	4,980	4,660	280	280	240	500	2,000	8,622	3,720	24,684		
4,200	4,980	4,760	280	280	240	500	2,000	8,622	3,840	24,924		
4,300	4,980	4,860	280	280	240	500	2,000	8,622	3,960	25,164		
4,400	4,980	4,960	280	280	240	500	2,000	8,622	4,080	25,404		
4,500	4,980	5,060	280	280	240	500	2,000	8,622	4,200	25,644		
内幅 (b) 4,600~4,900までの製品も上記の寸法表の内高 (h) にて製造が可能です。												
5,000	5,000	1,500	5,560	2,100	300	300	280	*	2,000	10,890	—	21,780
		1,600	5,560	2,200	300	300	280	*	2,000	11,030	—	22,060
		1,700	5,560	2,300	300	300	280	*	2,000	11,170	—	22,340
		1,800	5,560	2,400	300	300	280	*	2,000	11,310	—	22,620
		1,900	5,560	2,500	300	300	280	*	2,000	11,450	—	22,900
		2,000	5,560	2,600	300	300	280	*	2,000	11,590	—	23,180
		2,100	5,560	2,700	300	300	280	*	2,000	11,730	—	23,460
		2,200	5,560	2,800	300	300	280	*	2,000	11,870	—	23,740
		2,300	5,560	2,900	300	300	280	*	2,000	12,010	—	24,020
		2,400	5,560	3,000	300	300	280	*	2,000	12,150	—	24,300
		2,500	5,560	3,100	300	300	280	*	2,000	12,290	—	24,580
		2,600	5,560	3,200	300	300	280	*	2,000	12,430	—	24,860
		2,700	5,560	3,300	300	300	280	*	2,000	12,570	—	25,140
		2,800	5,560	3,400	300	300	280	*	2,000	12,710	—	25,420
		2,900	5,560	3,500	300	300	280	*	2,000	12,850	—	25,700
		3,000	5,560	3,600	300	300	280	*	2,000	12,990	—	25,980
		3,100	5,560	3,700	300	300	280	*	2,000	13,130	—	26,260
		3,200	5,560	3,800	300	300	280	*	2,000	13,270	—	26,540
		3,300	5,560	3,900	300	300	280	*	2,000	13,410	—	26,820
		3,400	5,560	4,000	300	300	280	*	2,000	13,550	—	27,100
		3,500	5,560	4,100	300	300	280	*	2,000	13,690	—	27,380
		3,600	5,560	4,200	300	300	280	*	2,000	13,830	—	27,660
		3,700	5,560	4,300	300	300	280	*	2,000	13,970	—	27,940
		3,800	5,560	4,400	300	300	280	*	2,000	14,110	—	28,220
		3,900	5,560	4,500	300	300	280	*	2,000	14,250	—	28,500
		4,000	5,560	4,600	300	300	280	*	2,000	14,390	—	28,780
4,100	5,560	4,700	300	300	280	500	2,000	10,190	4,340	29,060		
4,200	5,560	4,800	300	300	280	500	2,000	10,190	4,480	29,340		
4,300	5,560	4,900	300	300	280	500	2,000	10,190	4,620	29,620		
4,400	5,560	5,000	300	300	280	500	2,000	10,190	4,760	29,900		
4,500	5,560	5,100	300	300	280	500	2,000	10,190	4,900	30,180		

形状寸法及び製品質量

製品サイズ	内幅 b (mm)	内高 h (mm)	全幅 B (mm)	全高 H (mm)	頂版厚 t1 (mm)	底版厚 t2 (mm)	側壁厚 t3 (mm)	接続位置 h1 (mm)	製品長 L (mm)	頂底版 (kg/本)	側版 (kg/本)	1組質量 (kg/本)
5,000	5,000	4,600	5,560	5,200	300	300	280	500	2,000	10,190	5,040	30,460
		4,700	5,560	5,300	300	300	280	500	2,000	10,190	5,180	30,740
		4,800	5,560	5,400	300	300	280	500	2,000	10,190	5,320	31,020
		4,900	5,560	5,500	300	300	280	500	2,000	10,190	5,460	31,300
		5,000	5,560	5,600	300	300	280	500	2,000	10,190	5,600	31,580
内幅 (b) 5,100~5,400までの製品も上記の寸法表の内高 (h) にて製造が可能です。												
5,500	5,500	1,500	6,060	2,140	320	320	280	*	1,000	6,123	—	12,246
		1,600	6,060	2,240	320	320	280	*	1,000	6,193	—	12,386
		1,700	6,060	2,340	320	320	280	*	1,000	6,263	—	12,526
		1,800	6,060	2,440	320	320	280	*	1,000	6,333	—	12,666
		1,900	6,060	2,540	320	320	280	*	1,000	6,403	—	12,806
		2,000	6,060	2,640	320	320	280	*	1,000	6,473	—	12,946
		2,100	6,060	2,740	320	320	280	*	1,000	6,543	—	13,086
		2,200	6,060	2,840	320	320	280	*	1,000	6,613	—	13,226
		2,300	6,060	2,940	320	320	280	*	1,000	6,683	—	13,366
		2,400	6,060	3,040	320	320	280	*	1,000	6,753	—	13,506
		2,500	6,060	3,140	320	320	280	*	1,000	6,823	—	13,646
		2,600	6,060	3,240	320	320	280	*	1,000	6,893	—	13,786
		2,700	6,060	3,340	320	320	280	*	1,000	6,963	—	13,926
		2,800	6,060	3,440	320	320	280	*	1,000	7,033	—	14,066
		2,900	6,060	3,540	320	320	280	*	1,000	7,103	—	14,206
		3,000	6,060	3,640	320	320	280	*	1,000	7,173	—	14,346
		3,100	6,060	3,740	320	320	280	*	1,000	7,243	—	14,486
		3,200	6,060	3,840	320	320	280	*	1,000	7,313	—	14,626
		3,300	6,060	3,940	320	320	280	*	1,000	7,383	—	14,766
		3,400	6,060	4,040	320	320	280	*	1,000	7,453	—	14,906
		3,500	6,060	4,140	320	320	280	*	1,000	7,523	—	15,046
		3,600	6,060	4,240	320	320	280	*	1,000	7,593	—	15,186
		3,700	6,060	4,340	320	320	280	*	1,000	7,663	—	15,326
		3,800	6,060	4,440	320	320	280	*	1,000	7,733	—	15,466
		3,900	6,060	4,540	320	320	280	*	1,000	7,803	—	15,606
		4,000	6,060	4,640	320	320	280	*	1,000	7,813	—	15,746
4,100	6,060	4,740	320	320	280	500	1,000	5,773	2,170	15,886		
4,200	6,060	4,840	320	320	280	500	1,000	5,773	2,240	16,026		
4,300	6,060	4,940	320	320	280	500	1,000	5,773	2,310	16,166		
4,400	6,060	5,040	320	320	280	500	1,000	5,773	2,380	16,306		
4,500	6,060	5,140	320	320	280	500	1,000	5,773	2,450	16,446		
4,600	6,060	5,240	320	320	280	500	1,000	5,773	2,520	16,586		
4,700	6,060	5,340	320	320	280	500	1,000	5,773	2,590	16,726		
4,800	6,060	5,440	320	320	280	500	1,000	5,773	2,660	16,866		
4,900	6,060	5,540	320	320	280	500	1,000	5,773	2,730	17,006		
5,000	6,060	5,640	320	320	280	500	1,000	5,773	2,800	17,146		
内幅 (b) 5,600~5,900までの製品も上記の寸法表の内高 (h) にて製造が可能です。												
6,000	6,000	1,500	6,640	2,180	340	340	320	*	1,000	7,069	—	14,138
		1,600	6,640	2,280	340	340	320	*	1,000	7,149	—	14,298
		1,700	6,640	2,380	340	340	320	*	1,000	7,229	—	14,458
		1,800	6,640	2,480	340	340	320	*	1,000	7,309	—	14,618
		1,900	6,640	2,580	340	340	320	*	1,000	7,389	—	14,778
		2,000	6,640	2,680	340	340	320	*	1,000	7,469	—	14,938
		2,100	6,640	2,780	340	340	320	*	1,000	7,549	—	15,098
		2,200	6,640	2,880	340	340	320	*	1,000	7,629	—	15,258
		2,300	6,640	2,980	340	340	320	*	1,000	7,709	—	15,418
		2,400	6,640	3,080	340	340	320	*	1,000	7,789	—	15,578
		2,500	6,640	3,180	340	340	320	*	1,000	7,869	—	15,738
		2,600	6,640	3,280	340	340	320	*	1,000	7,949	—	15,898
		2,700	6,640	3,380	340	340	320	*	1,000	8,029	—	16,058
		2,800	6,640	3,480	340	340	320	*	1,000	8,109	—	16,218
		2,900	6,640	3,580	340	340	320	*	1,000	8,189	—	16,378
		3,000	6,640	3,680	340	340	320	*	1,000	8,269	—	16,538
		3,100	6,640	3,780	340	340	320	*	1,000	8,349	—	16,698
		3,200	6,640	3,880	340	340	320	*	1,000	8,429	—	16,858
		3,300	6,640	3,980	340	340	320	*	1,000	8,509	—	17,018
		3,400	6,640	4,080	340	340	320	*	1,000	8,589	—	17,178
		3,500	6,640	4,180	340	340	320	*	1,000	8,669	—	17,338
		3,600	6,640	4,280	340	340	320	*	1,000	8,749	—	17,498
		3,700	6,640	4,380	340	340	320	*	1,000	8,829	—	17,658
		3,800	6,640	4,480	340	340	320	*	1,000	8,909	—	17,818
		3,900	6,640	4,580	340	340	320	*	1,000	8,989	—	17,978
		4,000	6,640	4,680	340	340	320	*	1,000	9,069	—	18,138
4,100	6,640	4,780	340	340	320	500	1,000	6,669	2,480	18,298		
4,200	6,640	4,880	340	340	320	500	1,000	6,669	2,560	18,458		

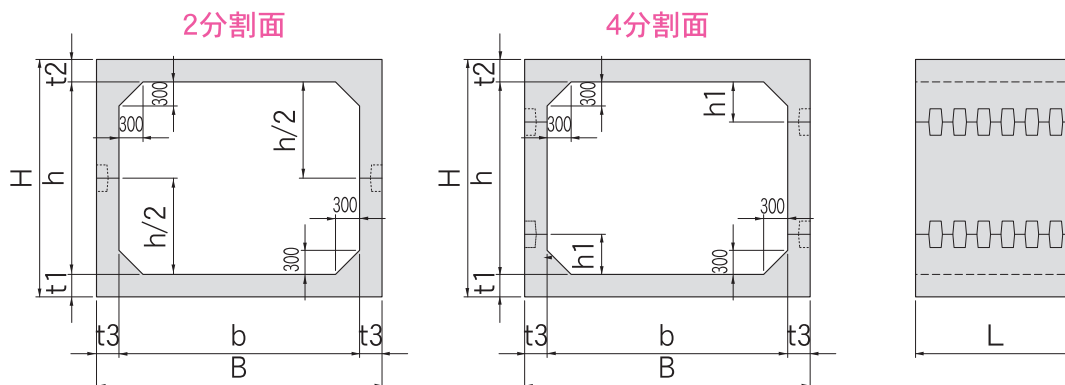

形状寸法及び製品質量

製品サイズ	内幅 b (mm)	内高 h (mm)	全幅 B (mm)	全高 H (mm)	頂版厚 t1 (mm)	底版厚 t2 (mm)	側壁厚 t3 (mm)	接続位置 h1 (mm)	製品長 L (mm)	頂底版 (kg/本)	側版 (kg/本)	1組質量 (kg/本)
6,000	6,000	4,300	6,640	4,980	340	340	320	500	1,000	6,669	2,580	18,618
		4,400	6,640	5,080	340	340	320	500	1,000	6,669	2,720	18,778
		4,500	6,640	5,180	340	340	320	500	1,000	6,669	2,800	18,938
		4,600	6,640	5,280	340	340	320	500	1,000	6,669	2,880	19,098
		4,700	6,640	5,380	340	340	320	500	1,000	6,669	2,960	19,258
		4,800	6,640	5,480	340	340	320	500	1,000	6,669	3,040	19,418
		4,900	6,640	5,580	340	340	320	500	1,000	6,669	3,120	19,578
		5,000	6,640	5,680	340	340	320	500	1,000	6,669	3,200	19,738
内幅 (b) 6,100~6,400までの製品も上記の寸法表の内高 (h) にて製造が可能です。												
6,500	6,500	1,500	7,140	2,260	380	380	320	*	1,000	8,208	—	16,416
		1,600	7,140	2,360	380	380	320	*	1,000	8,288	—	16,576
		1,700	7,140	2,420	360	360	320	*	1,000	8,011	—	16,022
		1,800	7,140	2,520	360	360	320	*	1,000	8,091	—	16,182
		1,900	7,140	2,620	360	360	320	*	1,000	8,171	—	16,342
		2,000	7,140	2,720	360	360	320	*	1,000	8,251	—	16,502
		2,100	7,140	2,820	360	360	320	*	1,000	8,331	—	16,662
		2,200	7,140	2,920	360	360	320	*	1,000	8,411	—	16,822
		2,300	7,140	3,020	360	360	320	*	1,000	8,491	—	16,982
		2,400	7,140	3,120	360	360	320	*	1,000	8,571	—	17,142
		2,500	7,140	3,220	360	360	320	*	1,000	8,651	—	17,302
		2,600	7,140	3,320	360	360	320	*	1,000	8,731	—	17,462
		2,700	7,140	3,420	360	360	320	*	1,000	8,811	—	17,622
		2,800	7,140	3,520	360	360	320	*	1,000	8,891	—	17,782
		2,900	7,140	3,620	360	360	320	*	1,000	8,971	—	17,942
		3,000	7,140	3,720	360	360	320	*	1,000	9,051	—	18,102
		3,100	7,140	3,820	360	360	320	*	1,000	9,131	—	18,262
		3,200	7,140	3,920	360	360	320	*	1,000	9,211	—	18,422
		3,300	7,140	4,020	360	360	320	*	1,000	9,291	—	18,582
		3,400	7,140	4,120	360	360	320	*	1,000	9,371	—	18,742
		3,500	7,140	4,220	360	360	320	*	1,000	9,451	—	18,902
		3,600	7,140	4,320	360	360	320	*	1,000	9,531	—	19,062
		3,700	7,140	4,420	360	360	320	*	1,000	9,611	—	19,222
3,800	7,140	4,520	360	360	320	*	1,000	9,691	—	19,382		
3,900	7,140	4,620	360	360	320	*	1,000	9,771	—	19,542		
4,000	7,140	4,720	360	360	320	*	1,000	9,851	—	19,702		
4,100	7,140	4,820	360	360	320	500	1,000	7,451	2,480	19,862		
4,200	7,140	4,920	360	360	320	500	1,000	7,451	2,560	20,022		
4,300	7,140	5,020	360	360	320	500	1,000	7,451	2,640	20,182		
4,400	7,140	5,120	360	360	320	500	1,000	7,451	2,720	20,342		
4,500	7,140	5,220	360	360	320	500	1,000	7,451	2,800	20,502		
4,600	7,140	5,320	360	360	320	500	1,000	7,451	2,880	20,662		
4,700	7,140	5,420	360	360	320	500	1,000	7,451	2,960	20,822		
4,800	7,140	5,520	360	360	320	500	1,000	7,451	3,040	20,982		
4,900	7,140	5,620	360	360	320	500	1,000	7,451	3,120	21,142		
5,000	7,140	5,720	360	360	320	500	1,000	7,451	3,200	21,302		
内幅 (b) 6,600~6,900までの製品も上記の寸法表の内高 (h) にて製造が可能です。												
7,000	7,000	1,500	7,720	2,300	400	400	360	*	1,000	9,295	—	18,590
		1,600	7,720	2,400	400	400	360	*	1,000	9,385	—	18,770
		1,700	7,720	2,500	400	400	360	*	1,000	9,475	—	18,950
		1,800	7,720	2,600	400	400	360	*	1,000	9,565	—	19,130
		1,900	7,720	2,700	400	400	360	*	1,000	9,655	—	19,310
		2,000	7,720	2,800	400	400	360	*	1,000	9,745	—	19,490
		2,100	7,720	2,860	380	380	360	*	1,000	9,449	—	18,898
		2,200	7,720	2,960	380	380	360	*	1,000	9,539	—	19,078
		2,300	7,720	3,060	380	380	360	*	1,000	9,629	—	19,258
		2,400	7,720	3,160	380	380	360	*	1,000	9,719	—	19,438
		2,500	7,720	3,260	380	380	360	*	1,000	9,809	—	19,618

形状寸法及び製品質量

製品サイズ	内幅 b(mm)	内高 h(mm)	全幅 B(mm)	全高 H(mm)	頂版厚 t1(mm)	底版厚 t2(mm)	側壁厚 t3(mm)	接続位置 h1(mm)	製品長 L(mm)	頂底版 (kg/本)	側版 (kg/本)	1組質量 (kg/本)
7,000	7,000	2,600	7,720	3,360	380	380	360	*	1,000	9,899	—	19,798
		2,700	7,720	3,460	380	380	360	*	1,000	9,989	—	19,978
		2,800	7,720	3,560	380	380	360	*	1,000	10,079	—	20,158
		2,900	7,720	3,660	380	380	360	*	1,000	10,169	—	20,338
		3,000	7,720	3,760	380	380	360	*	1,000	10,259	—	20,518
		3,100	7,720	3,860	380	380	360	*	1,000	10,349	—	20,698
		3,200	7,720	3,960	380	380	360	*	1,000	10,439	—	20,878
		3,300	7,720	4,060	380	380	360	*	1,000	10,529	—	21,058
		3,400	7,720	4,160	380	380	360	*	1,000	10,619	—	21,238
		3,500	7,720	4,260	380	380	360	*	1,000	10,709	—	21,418
		3,600	7,720	4,360	380	380	360	*	1,000	10,799	—	21,598
		3,700	7,720	4,460	380	380	360	*	1,000	10,889	—	21,778
		3,800	7,720	4,560	380	380	360	*	1,000	10,979	—	21,958
		3,900	7,720	4,660	380	380	360	*	1,000	11,069	—	22,138
		4,000	7,720	4,760	380	380	360	*	1,000	11,159	—	22,318
		4,100	7,720	4,860	380	380	360	500	1,000	8,459	2,790	22,498
		4,200	7,720	4,960	380	380	360	500	1,000	8,459	2,880	22,678
		4,300	7,720	5,060	380	380	360	500	1,000	8,459	2,970	22,858
		4,400	7,720	5,160	380	380	360	500	1,000	8,459	3,060	23,038
		4,500	7,720	5,260	380	380	360	500	1,000	8,459	3,150	23,218
4,600	7,720	5,360	380	380	360	500	1,000	8,459	3,240	23,398		
4,700	7,720	5,460	380	380	360	500	1,000	8,459	3,330	23,578		
4,800	7,720	5,560	380	380	360	500	1,000	8,459	3,420	23,758		
4,900	7,720	5,660	380	380	360	500	1,000	8,459	3,510	23,938		
5,000	7,720	5,760	380	380	360	500	1,000	8,459	3,600	24,118		
内幅 (b) 7,100~7,400までの製品も上記の寸法表の内高 (h) にて製造が可能です。												
7,500	7,500	1,500	8,220	2,460	480	480	360	*	1,000	11,439	—	22,878
		1,600	8,220	2,560	480	480	360	*	1,000	11,529	—	23,058
		1,700	8,220	2,660	480	480	360	*	1,000	11,619	—	23,238
		1,800	8,220	2,760	480	480	360	*	1,000	11,709	—	23,418
		1,900	8,220	2,820	460	460	360	*	1,000	11,388	—	22,776
		2,000	8,220	2,920	460	460	360	*	1,000	11,478	—	22,956
		2,100	8,220	2,980	440	440	360	*	1,000	11,157	—	22,314
		2,200	8,220	3,080	440	440	360	*	1,000	11,247	—	22,494
		2,300	8,220	3,180	440	440	360	*	1,000	11,337	—	22,674
		2,400	8,220	3,280	440	440	360	*	1,000	11,427	—	22,854
		2,500	8,220	3,340	420	420	360	*	1,000	11,106	—	22,212
		2,600	8,220	3,440	420	420	360	*	1,000	11,196	—	22,392
		2,700	8,220	3,540	420	420	360	*	1,000	11,286	—	22,572
		2,800	8,220	3,640	420	420	360	*	1,000	11,376	—	22,752
		2,900	8,220	3,740	420	420	360	*	1,000	11,466	—	22,932
		3,000	8,220	3,840	420	420	360	*	1,000	11,556	—	23,112
		3,100	8,220	3,940	420	420	360	*	1,000	11,646	—	23,292
		3,200	8,220	4,040	420	420	360	*	1,000	11,736	—	23,472
		3,300	8,220	4,140	420	420	360	*	1,000	11,826	—	23,652
		3,400	8,220	4,240	420	420	360	*	1,000	11,916	—	23,832
		3,500	8,220	4,340	420	420	360	*	1,000	12,006	—	24,012
		3,600	8,220	4,440	420	420	360	*	1,000	12,096	—	24,192
		3,700	8,220	4,540	420	420	360	*	1,000	12,186	—	24,372
		3,800	8,220	4,640	420	420	360	*	1,000	12,276	—	24,552
3,900	8,220	4,740	420	420	360	*	1,000	12,366	—	24,732		
4,000	8,220	4,840	420	420	360	*	1,000	12,456	—	24,912		
4,100	8,220	4,940	420	420	360	500	1,000	9,756	2,790	25,092		
4,200	8,220	5,040	420	420	360	500	1,000	9,756	2,880	25,272		
4,300	8,220	5,140	420	420	360	500	1,000	9,756	2,970	25,452		
4,400	8,220	5,240	420	420	360	500	1,000	9,756	3,060	25,632		
4,500	8,220	5,340	420	420	360	500	1,000	9,756	3,150	25,812		
4,600	8,220	5,440	420	420	360	500	1,000	9,756	3,240	25,992		
4,700	8,220	5,540	420	420	360	500	1,000	9,756	3,330	26,172		
4,800	8,220	5,640	420	420	360	500	1,000	9,756	3,420	26,352		
4,900	8,220	5,740	420	420	360	500	1,000	9,756	3,510	26,532		
5,000	8,220	5,840	420	420	360	500	1,000	9,756	3,600	26,712		
内幅 (b) 7,600~7,900までの製品も上記の寸法表の内高 (h) にて製造が可能です。												
8,000	8,000	1,500	8,800	2,580	540	540	400	*	1,000	13,605	—	27,210
		1,600	8,800	2,680	540	540	400	*	1,000	13,705	—	27,410
		1,700	8,800	2,780	540	540	400	*	1,000	13,805	—	27,610
		1,800	8,800	2,840	520	520	400	*	1,000	13,465	—	26,930
		1,900	8,800	2,940	520	520	400	*	1,000	13,565	—	27,130
		2,000	8,800	3,040	520	520	400	*	1,000	13,665	—	27,330
		2,100	8,800	3,100	500	500	400	*	1,000	13,325	—	26,650
		2,200	8,800	3,200	500	500	400	*	1,000	13,425	—	26,850
		2,300	8,800	3,300	500	500	400	*	1,000	13,525	—	27,050
2,400	8,800	3,400	500	500	400	*	1,000	13,625	—	27,250		

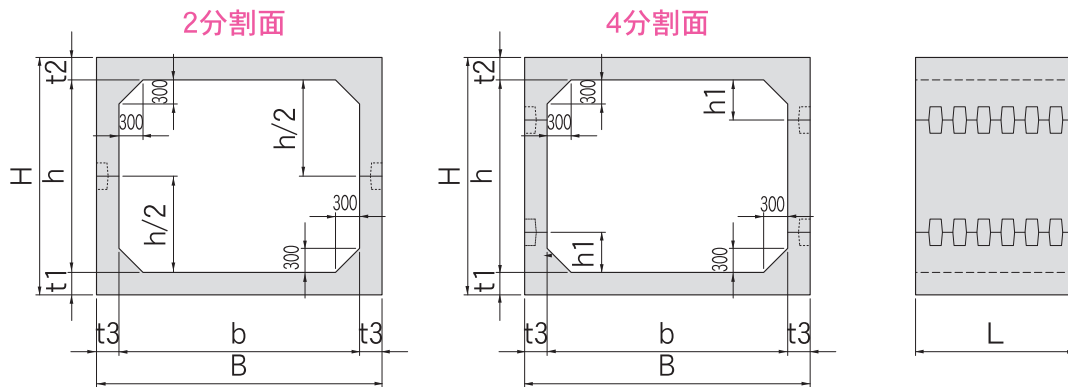

形状寸法及び製品質量

製品サイズ	内幅 b (mm)	内高 h (mm)	全幅 B (mm)	全高 H (mm)	頂版厚 t1 (mm)	底版厚 t2 (mm)	側壁厚 t3 (mm)	接続位置 h1 (mm)	製品長 L (mm)	頂底版 (kg/本)	側版 (kg/本)	1組質量 (kg/本)
8,000	8,000	2,500	8,800	3,460	480	480	400	*	1,000	13,285	—	26,570
		2,600	8,800	3,560	480	480	400	*	1,000	13,385	—	26,770
		2,700	8,800	3,660	480	480	400	*	1,000	13,485	—	26,970
		2,800	8,800	3,760	480	480	400	*	1,000	13,585	—	27,170
		2,900	8,800	3,860	480	480	400	*	1,000	13,685	—	27,370
		3,000	8,800	3,960	480	480	400	*	1,000	13,785	—	27,570
		3,100	8,800	4,020	460	460	400	*	1,000	13,445	—	26,890
		3,200	8,800	4,120	460	460	400	*	1,000	13,545	—	27,090
		3,300	8,800	4,220	460	460	400	*	1,000	13,645	—	27,290
		3,400	8,800	4,320	460	460	400	*	1,000	13,745	—	27,490
		3,500	8,800	4,420	460	460	400	*	1,000	13,845	—	27,690
		3,600	8,800	4,520	460	460	400	*	1,000	13,945	—	27,890
		3,700	8,800	4,620	460	460	400	*	1,000	14,045	—	28,090
		3,800	8,800	4,720	460	460	400	*	1,000	14,145	—	28,290
		3,900	8,800	4,820	460	460	400	*	1,000	14,245	—	28,490
		4,000	8,800	4,920	460	460	400	*	1,000	14,345	—	28,690
		4,100	8,800	5,020	460	460	400	500	1,000	11,345	3,100	28,890
		4,200	8,800	5,120	460	460	400	500	1,000	11,345	3,200	29,090
		4,300	8,800	5,220	460	460	400	500	1,000	11,345	3,300	29,290
		4,400	8,800	5,320	460	460	400	500	1,000	11,345	3,400	29,490
4,500	8,800	5,420	460	460	400	500	1,000	11,345	3,500	29,690		
4,600	8,800	5,520	460	460	400	500	1,000	11,345	3,600	29,890		
4,700	8,800	5,620	460	460	400	500	1,000	11,345	3,700	30,090		
4,800	8,800	5,720	460	460	400	500	1,000	11,345	3,800	30,290		
4,900	8,800	5,820	460	460	400	500	1,000	11,345	3,900	30,490		
5,000	8,800	5,920	460	460	400	500	1,000	11,345	4,000	30,690		
内幅 (b) 8,100~8,400までの製品も上記の寸法表の内高 (h) にて製造が可能です。												
8,500	8,500	1,500	9,300	2,700	600	600	400	*	1,000	15,675	—	31,350
		1,600	9,300	2,800	600	600	400	*	1,000	15,775	—	31,550
		1,700	9,300	2,900	600	600	400	*	1,000	15,875	—	31,750
		1,800	9,300	2,960	580	580	400	*	1,000	15,510	—	31,020
		1,900	9,300	3,060	580	580	400	*	1,000	15,610	—	31,220
		2,000	9,300	3,160	580	580	400	*	1,000	15,710	—	31,420
		2,100	9,300	3,220	560	560	400	*	1,000	15,345	—	30,690
		2,200	9,300	3,320	560	560	400	*	1,000	15,445	—	30,880
		2,300	9,300	3,420	560	560	400	*	1,000	15,545	—	31,090
		2,400	9,300	3,480	540	540	400	*	1,000	15,180	—	30,360
		2,500	9,300	3,580	540	540	400	*	1,000	15,280	—	30,560
		2,600	9,300	3,680	540	540	400	*	1,000	15,380	—	30,760
		2,700	9,300	3,780	540	540	400	*	1,000	15,480	—	30,960
		2,800	9,300	3,880	540	540	400	*	1,000	15,580	—	31,160
		2,900	9,300	3,940	520	520	400	*	1,000	15,215	—	30,430
		3,000	9,300	4,040	520	520	400	*	1,000	15,315	—	30,630
		3,100	9,300	4,140	520	520	400	*	1,000	15,415	—	30,830
		3,200	9,300	4,240	520	520	400	*	1,000	15,515	—	31,030
		3,300	9,300	4,340	520	520	400	*	1,000	15,615	—	31,230
		3,400	9,300	4,440	520	520	400	*	1,000	15,715	—	31,430
		3,500	9,300	4,540	520	520	400	*	1,000	15,815	—	31,630
		3,600	9,300	4,640	520	520	400	*	1,000	15,915	—	31,830
		3,700	9,300	4,740	520	520	400	*	1,000	16,015	—	32,030
		3,800	9,300	4,840	520	520	400	*	1,000	16,115	—	32,230
3,900	9,300	4,940	520	520	400	*	1,000	16,215	—	32,430		
4,000	9,300	5,040	520	520	400	*	1,000	16,315	—	32,630		
4,100	9,300	5,140	520	520	400	500	1,000	13,315	3,100	32,830		
4,200	9,300	5,240	520	520	400	500	1,000	13,315	3,200	33,030		
4,300	9,300	5,340	520	520	400	500	1,000	13,315	3,300	33,230		
4,400	9,300	5,440	520	520	400	500	1,000	13,315	3,400	33,430		

形状寸法及び製品質量

製品サイズ	内幅 b(mm)	内高 h(mm)	全幅 B(mm)	全高 H(mm)	頂版厚 t1(mm)	底版厚 t2(mm)	側壁厚 t3(mm)	接続位置 h1(mm)	製品長 L(mm)	頂底版 (kg/本)	側版 (kg/本)	1組質量 (kg/本)
8,500	8,500	4,500	9,300	5,540	520	520	400	500	1,000	13,315	3,500	33,630
		4,600	9,300	5,640	520	520	400	500	1,000	13,315	3,600	33,830
		4,700	9,300	5,740	520	520	400	500	1,000	13,315	3,700	34,030
		4,800	9,300	5,840	520	520	400	500	1,000	13,315	3,800	34,230
		4,900	9,300	5,940	520	520	400	500	1,000	13,315	3,900	34,430
		5,000	9,300	6,040	520	520	400	500	1,000	13,315	4,000	34,630
内幅 (b) 8,600~8,900までの製品も上記の寸法表の内高 (h) にて製造が可能です。												
9,000	9,000	1,500	9,880	2,860	680	680	440	*	1,000	18,671	—	37,342
		1,600	9,880	2,960	680	680	440	*	1,000	18,781	—	37,562
		1,700	9,880	3,060	680	680	440	*	1,000	18,891	—	37,782
		1,800	9,880	3,160	680	680	440	*	1,000	19,001	—	38,002
		1,900	9,880	3,180	640	640	440	*	1,000	18,123	—	36,246
		2,000	9,880	3,280	640	640	440	*	1,000	18,233	—	36,466
		2,100	9,880	3,380	640	640	440	*	1,000	18,343	—	36,686
		2,200	9,880	3,480	640	640	440	*	1,000	18,453	—	36,906
		2,300	9,880	3,580	640	640	440	*	1,000	18,563	—	37,126
		2,400	9,880	3,680	640	640	440	*	1,000	18,783	—	37,346
		2,500	9,880	3,780	640	640	440	*	1,000	18,673	—	37,566
		2,600	9,880	3,800	600	600	440	*	1,000	17,905	—	35,810
		2,700	9,880	3,900	600	600	440	*	1,000	18,015	—	36,030
		2,800	9,880	4,000	600	600	440	*	1,000	18,125	—	36,250
		2,900	9,880	4,100	600	600	440	*	1,000	18,235	—	36,470
		3,000	9,880	4,200	600	600	440	*	1,000	18,345	—	36,690
		3,100	9,880	4,260	580	580	440	*	1,000	17,961	—	35,922
		3,200	9,880	4,360	580	580	440	*	1,000	18,071	—	36,142
		3,300	9,880	4,460	580	580	440	*	1,000	18,181	—	36,362
		3,400	9,880	4,560	580	580	440	*	1,000	18,291	—	36,582
		3,500	9,880	4,660	580	580	440	*	1,000	18,401	—	36,802
		3,600	9,880	4,760	580	580	440	*	1,000	18,511	—	37,022
		3,700	9,880	4,860	580	580	440	*	1,000	18,621	—	37,242
		3,800	9,880	4,960	580	580	440	*	1,000	18,731	—	37,462
		3,900	9,880	5,060	580	580	440	*	1,000	18,841	—	37,682
		4,000	9,880	5,160	580	580	440	*	1,000	18,951	—	37,902
		4,100	9,880	5,260	580	580	440	500	1,000	15,651	3,410	38,122
		4,200	9,880	5,360	580	580	440	500	1,000	15,651	3,520	38,342
		4,300	9,880	5,460	580	580	440	500	1,000	15,651	3,630	38,562
		4,400	9,880	5,560	580	580	440	500	1,000	15,651	3,740	38,782
4,500	9,880	5,660	580	580	440	500	1,000	15,651	3,850	39,002		
4,600	9,880	5,760	580	580	440	500	1,000	15,651	3,960	39,222		
4,700	9,880	5,860	580	580	440	500	1,000	15,651	4,070	39,442		
4,800	9,880	5,960	580	580	440	500	1,000	15,651	4,180	39,662		
4,900	9,880	6,060	580	580	440	500	1,000	15,651	4,290	39,882		
5,000	9,880	6,160	580	580	440	500	1,000	15,651	4,400	40,102		
内幅 (b) 9,100~9,400までの製品も上記の寸法表の内高 (h) にて製造が可能です。												



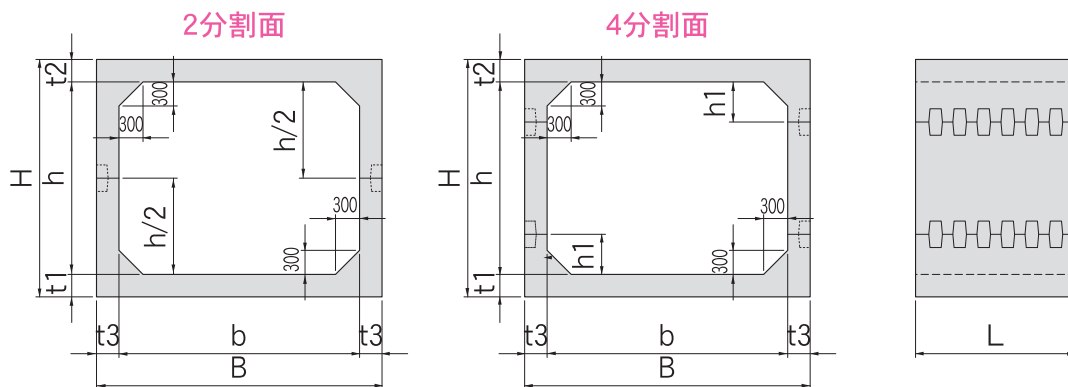

形状寸法及び製品質量

製品サイズ	内幅 b (mm)	内高 h (mm)	全幅 B (mm)	全高 H (mm)	頂版厚 t1 (mm)	底版厚 t2 (mm)	側壁厚 t3 (mm)	接続位置 h1 (mm)	製品長 L (mm)	頂底版 (kg/本)	側版 (kg/本)	1組質量 (kg/本)
9,500	9,500	1,700	10,380	3,140	720	720	440	*	1,000	20,779	—	41,558
		1,800	10,380	3,240	720	720	440	*	1,000	20,889	—	41,778
		1,900	10,380	3,340	720	720	440	*	1,000	20,999	—	41,998
		2,000	10,380	3,440	720	720	440	*	1,000	21,109	—	42,218
		2,100	10,380	3,540	720	720	440	*	1,000	21,219	—	42,438
		2,200	10,380	3,560	680	680	440	*	1,000	20,291	—	40,582
		2,300	10,380	3,660	680	680	440	*	1,000	20,401	—	40,802
		2,400	10,380	3,760	680	680	440	*	1,000	20,511	—	41,022
		2,500	10,380	3,860	680	680	440	*	1,000	20,621	—	41,242
		2,600	10,380	3,960	680	680	440	*	1,000	20,731	—	41,462
		2,700	10,380	4,060	680	680	440	*	1,000	20,841	—	41,682
		2,800	10,380	4,160	680	680	440	*	1,000	20,951	—	41,902
		2,900	10,380	4,260	680	680	440	*	1,000	21,061	—	42,122
		3,000	10,380	4,280	640	640	440	*	1,000	20,133	—	40,266
		3,100	10,380	4,380	640	640	440	*	1,000	20,243	—	40,486
		3,200	10,380	4,480	640	640	440	*	1,000	20,353	—	40,706
		3,300	10,380	4,580	640	640	440	*	1,000	20,463	—	40,926
		3,400	10,380	4,680	640	640	440	*	1,000	20,573	—	41,146
		3,500	10,380	4,780	640	640	440	*	1,000	20,683	—	41,366
		3,600	10,380	4,880	640	640	440	*	1,000	20,793	—	41,586
		3,700	10,380	4,980	640	640	440	*	1,000	20,903	—	41,806
		3,800	10,380	5,080	640	640	440	*	1,000	21,013	—	42,026
		3,900	10,380	5,180	640	640	440	*	1,000	21,123	—	42,246
		4,000	10,380	5,280	640	640	440	*	1,000	21,233	—	42,466
		4,100	10,380	5,380	640	640	440	500	1,000	17,933	3,410	42,686
		4,200	10,380	5,480	640	640	440	500	1,000	17,933	3,520	42,906
		4,300	10,380	5,580	640	640	440	500	1,000	17,933	3,630	43,126
		4,400	10,380	5,680	640	640	440	500	1,000	17,933	3,740	43,346
		4,500	10,380	5,780	640	640	440	500	1,000	17,933	3,850	43,566
		4,600	10,380	5,880	640	640	440	500	1,000	17,933	3,960	43,786
4,700	10,380	5,980	640	640	440	500	1,000	17,933	4,070	44,006		
4,800	10,380	6,080	640	640	440	500	1,000	17,933	4,180	44,226		
4,900	10,380	6,180	640	640	440	500	1,000	17,933	4,290	44,446		
5,000	10,380	6,280	640	640	440	500	1,000	17,933	4,400	44,666		

※※印の製品は2分割、その他は4分割製品です。1組質量は2×(頂底版質量+側版質量)となります。

※h1寸法は、4分割製品に適用します。2分割製品は、内高(h)の1/2の位置で接続となります。

※内幅(b)及び、内高(h)は100mmピッチで対応しております。

※製品質量は当社コンクリートを2.5tf/mとしての計算です。

※人孔、ステップ、横穴、アンカー差し筋等は別途承ります。



2分割式ボックスカルバート標準施工歩掛り

(10m当り)

製品長 (mm)	1組当り質量 (tf/組)	2分割製品										諸雑費率 (%)
		世 話 役 (人)	特殊作業員 (人)	普通作業員 (人)	KTジョイント		縦断ジョイント ヶ所数	保護モルタル充填量			トラッククレーン 運 転 (日)	
					タイプ	ヶ所数		KT内部 (リットル)	KT開口部 (m ³)	縦断開口部 (m ³)		
1,000	8～10 未満	2.0	6.2	4.86	D25	60	40	0.960	0.262	0.252	2.06	2.0
	10～12 未満	2.0	6.2	4.86	D25	60	40	0.960	0.262	0.252	2.06	
	12～14 未満	2.0	6.2	4.86	D25	60	40	0.960	0.262	0.252	2.06	
	14～16 未満	2.2	6.7	5.26	D25	60	40	0.960	0.262	0.252	2.26	
	16～18 未満	2.3	7.2	5.44	D32	60	40	3.480	0.382	0.252	2.42	
	18～20 未満	2.5	7.8	5.90	D38	60	40	6.420	0.626	0.252	2.62	
	20～22 未満	2.6	8.3	6.20	D38	60	40	6.420	0.626	0.252	2.72	
	22～24 未満	2.8	8.8	6.60	D38	60	40	6.420	0.626	0.252	2.92	
	24～28 未満	3.0	9.3	6.90	D38	60	40	6.420	0.626	0.252	3.12	
	28～32 未満	3.1	9.8	7.30	D38	60	40	6.420	0.626	0.252	3.22	
	32～36 未満	3.5	10.9	8.00	D38	60	60	6.420	0.626	0.378	3.62	
	36～40 未満	3.6	11.4	8.40	D38	60	60	6.420	0.626	0.378	3.72	
2,000	10～12 未満	1.0	3.0	2.56	D25	60	20	0.960	0.262	0.126	1.06	1.0
	12～14 未満	1.0	3.0	2.56	D25	60	20	0.960	0.262	0.126	1.06	
	14～16 未満	1.1	3.2	2.56	D25	60	20	0.960	0.262	0.126	1.16	
	16～18 未満	1.2	3.5	2.74	D32	60	20	3.480	0.382	0.126	1.32	
	18～20 未満	1.2	3.7	3.00	D38	60	20	6.420	0.626	0.126	1.32	
	20～22 未満	1.3	4.0	3.10	D38	60	20	6.420	0.626	0.126	1.42	
	22～24 未満	1.4	4.2	3.30	D38	60	20	6.420	0.626	0.126	1.52	
	24～28 未満	1.5	4.4	3.50	D38	60	20	6.420	0.626	0.126	1.62	
28～32 未満	1.6	4.7	3.60	D38	60	20	6.420	0.626	0.126	1.72		

4分割式ボックスカルバート標準施工歩掛り

(10m当り)

製品長 (mm)	1組当り質量 (tf/組)	4分割製品										諸雑費率 (%)
		世 話 役 (人)	特殊作業員 (人)	普通作業員 (人)	KTジョイント		縦断ジョイント ヶ所数	保護モルタル充填量			トラッククレーン 運 転 (日)	
					タイプ	ヶ所数		KT内部 (リットル)	KT開口部 (m ³)	縦断開口部 (m ³)		
1,000	8～10 未満	2.4	7.5	6.12	D25	120	40	1.920	0.523	0.252	2.52	2.0
	10～12 未満	2.4	7.5	6.12	D25	120	40	1.920	0.523	0.252	2.52	
	12～14 未満	2.4	7.5	6.12	D25	120	40	1.920	0.523	0.252	2.52	
	14～16 未満	2.6	8.1	6.52	D25	120	40	1.920	0.523	0.252	2.72	
	16～18 未満	2.8	8.8	6.78	D32	120	40	6.960	0.763	0.252	3.04	
	18～20 未満	3.0	9.4	7.30	D38	120	40	12.840	1.253	0.252	3.24	
	20～22 未満	3.2	10.0	7.80	D38	120	40	12.840	1.253	0.252	3.44	
	22～24 未満	3.4	10.7	8.20	D38	120	40	12.840	1.253	0.252	3.64	
	24～28 未満	3.6	11.3	8.60	D38	120	40	12.840	1.253	0.252	3.84	
	28～32 未満	3.8	11.9	9.10	D38	120	40	12.840	1.253	0.252	4.04	
	32～36 未満	4.2	13.1	9.90	D38	120	60	12.840	1.253	0.378	4.44	
	36～40 未満	4.4	13.8	10.40	D38	120	60	12.840	1.253	0.378	4.64	
2,000	10～12 未満	1.2	3.6	3.32	D25	120	20	1.920	0.523	0.126	1.32	1.0
	12～14 未満	1.2	3.6	3.32	D25	120	20	1.920	0.523	0.126	1.32	
	14～16 未満	1.3	3.9	3.52	D25	120	20	1.920	0.523	0.126	1.42	
	16～18 未満	1.4	4.2	3.48	D32	120	20	6.960	0.763	0.126	1.64	
	18～20 未満	1.5	4.5	3.80	D38	120	20	12.840	1.253	0.126	1.74	
	20～22 未満	1.6	4.8	4.00	D38	120	20	12.840	1.253	0.126	1.84	
	22～24 未満	1.7	5.1	4.20	D38	120	20	12.840	1.253	0.126	1.94	
	24～28 未満	1.8	5.4	4.40	D38	120	20	12.840	1.253	0.126	2.04	
28～32 未満	1.9	5.7	4.60	D38	120	20	12.840	1.253	0.126	2.14		

(注) 1.歩掛りは、分割式ボックスカルバートの施工作業であり、KTジョイントおよび縦断ジョイントの締付けを含む。また、床掘り、基礎（敷コンクリート、基礎砕石）、埋め戻しは含まない。

2.詳細計算により、KTジョイントのタイプおよび、ヶ所数に変更が生じた場合は、本歩掛りは適用できない。

3.保護モルタル充填工歩掛りは、次頁を参照の事。

4.トラッククレーンは賃料とする。

5.敷モルタル、基礎は別途必要量を計上する。

6.諸雑費は、レバブロック損料、保護モルタル充填機費用であり、労務費、トラッククレーン賃料の合計額に上表の率を乗じた金額を上限として計上する。

ジョイント内部保護モルタル（流動タイプ）充填1リットル当りの作業歩掛り

名称	規格	単位	数量		
			D25タイプ	D32タイプ	D38タイプ
普通作業員		人	0.1135	0.1145	0.1115
無収縮モルタル	圧縮強度 50N/mm ² 以上	リットル	1.2	1.2	1.2
充填用器具経費		式	1	1	1

※無収縮モルタルは一般に質量あたり単価（円/kg）のため、体積あたり単価（円/m³）に修正して計算する。

※保護モルタル充填の際に使用する充填機具は、ハンドミキサー、オイラー、攪拌容器等であり、これらについての経費は本体据付工の諸経費率に含むものとする。

※本歩掛りは、プレミックスタイプ無収縮モルタルを使用した場合の歩掛りである。

ジョイント開口部保護モルタル充填1m³当りの作業歩掛り（硬練りタイプ）

名称	規格	単位	数量
普通作業員		人	2.7
無収縮モルタル	圧縮強度 50N/mm ² 以上	m ³	1.2

※無収縮モルタルは一般に質量あたり単価（円/kg）のため、体積あたり単価（円/m³）に修正して計算する。

※本歩掛りは、プレミックスタイプ無収縮モルタルを使用した場合の歩掛りである。

KCV使用材料表【10m当り】

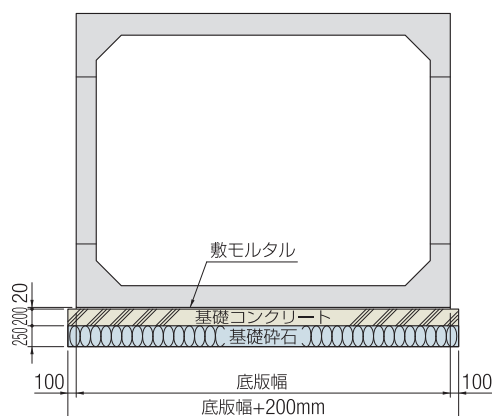

土被り0～10m

製品サイズ(幅×高さ)	10m当り材料表			
	基礎コンクリート (m ³)	基礎コン型枠 (m ²)	基礎砕石 (m ²)	敷モルタル (m ³)
300×150～300	7.200	4.000	36.000	0.680
350×150～350	8.200	4.000	41.000	0.780
400×150～400	9.360	4.000	46.800	0.896
450×150～450	10.360	4.000	51.800	0.996
500×150～500	11.520	4.000	57.600	1.112
550×150～500	12.520	4.000	62.600	1.212
600×150～500	13.680	4.000	68.400	1.328
650×150～500	14.680	4.000	73.400	1.428
700×150～500	15.840	4.000	79.200	1.544
750×150～500	16.840	4.000	84.200	1.644
800×150～500	18.000	4.000	90.000	1.760
850×150～500	19.000	4.000	95.000	1.860
900×150～500	20.160	4.000	100.800	1.976
950×170～500	21.160	4.000	105.800	2.076

※上記数値は、比較的良好的な通常地盤の場合を示します。

※堅固な地盤又は軟弱地盤の場合は、それに適した基礎工を採用してください。

施工写真

斜対応



内側ジョイント対応



二連



偏平

