

■豊富なサイズが有り、流量に合った断面を選択していただけます。

## 設計条件

### ① 載荷重

GSU :  $q=20\text{kN/m}^2$

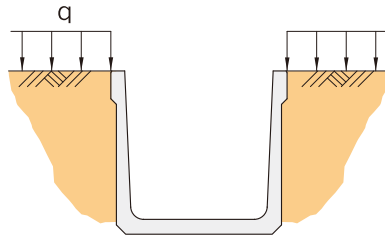

上記設計条件以外は別途ご相談ください。

### ② 断面形状

(Aタイプ)

(Bタイプ)

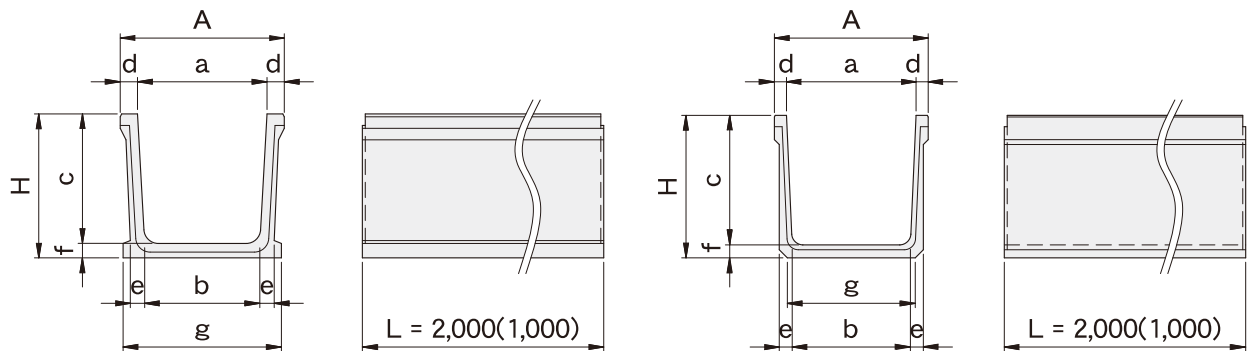

### ■ GSU-L

呼び名 (内幅×内高)	形状寸法 (mm)									質量 (kg/本)		タイプ 区分
	a	b	c	d	e	f	g	A	H	L=2m	L=1m	
GSU- 30× 30L	300	260	300	50	45	45	400	400	345	234	117	Aタイプ
GSU- 30× 50L		250	500	75	50	50	300	450	550	359	180	Bタイプ
GSU- 30× 60L		240	600	75	60	60	60	420	450	660	472	236
GSU- 40× 40L	400	360	400	60	45	45	500	520	445	309	154	Aタイプ
GSU- 40× 50L		350	500	75	50	50	400	550	550	384	192	Bタイプ
GSU- 40× 60L		340	600	75	60	60	520	550	660	501	250	Aタイプ
GSU- 45× 45L	450	400	450	60	50	50	550	570	500	366	183	Aタイプ
GSU- 50× 50L	500	450	500	75	50	50	500	650	550	409	205	Bタイプ
GSU- 60× 60L	600	540	600	75	60	60	600	750	660	539	269	



■GSU

呼び名 (内幅×内高)	形状寸法 (mm)									質量 (kg/本)		タイプ 区分
	a	b	c	d	e	f	g	A	H	L=2m	L=1m	
GSU- 50× 70	500	440	700	75	75	75	490	650	775	679	340	Bタイプ
GSU- 50× 80		430	800		80	80			880	780	390	
GSU- 60× 70	600	540	700	75	75	75	590	750	775	717	359	
GSU- 60× 80		530	800		80	80			880	820	410	
GSU- 60× 90		520	900		85	85			985	932	466	
GSU- 60×100		510	1,000		90	90			1,090	1,054	527	
GSU- 70× 60	700	640	600	75	75	75	690	850	675	685	343	
GSU- 70× 70		640	700		75	75			775	754	377	
GSU- 70×100		610	1,000		90	90			1,090	1,099	550	
GSU- 80× 50	800	750	500	75	70	70	790	950	570	628	314	
GSU- 80× 60		740	600		75	75			675	723	362	
GSU- 80× 70		740	700		75	75			775	792	396	
GSU- 80× 80		730	800		80	80			880	900	450	
GSU- 80× 90		720	900		85	85			985	1,017	509	
GSU- 80×100		710	1,000		90	90			1,090	1,143	572	
GSU- 80×120		700	1,200		95	95			1,295	1,331	666	
GSU- 90× 80		900	830		800	75			80	80	890	
GSU- 90× 90	820		900	85	85		985	1,060	530			
GSU-100× 60	1,000	940	600	75	75	75	990	1,150	675	798	399	
GSU-100× 70		940	700		75	75			775	867	434	
GSU-100× 80		930	800		80	80			880	980	490	
GSU-100× 90		920	900		85	85			985	1,103	551	
GSU-100×100		910	1,000		90	90			1,090	1,234	617	
GSU-100×120		900	1,200		95	95			1,295	1,423	712	
GSU-120× 60	1,200	1,140	600	75	75	75	1,190	1,350	675	871	436	
GSU-120× 80		1,130	800		80	80			880	1,060	530	
GSU-120× 90		1,120	900		85	85			985	1,188	594	
GSU-120×100		1,110	1,000		90	90			1,090	1,324	662	
GSU-120×120	1,100	1,200	95	95	1,295	1,518	759					
GSU-140×100	1,400	1,310	1,000	75	90	90	1,390	1,550	1,090	1,413	707	
GSU-140×120		1,300	1,200		95	95			1,295	1,616	808	
GSU-140×140		1,280	1,400		110	110			1,400	1,550	1,510	2,003
GSU-150×100	1,500	1,410	1,000	75	90	90	1,490	1,650	1,090	1,458	729	
GSU-150×120		1,400	1,200		95	95			1,295	1,661	830	
GSU-200× 90	2,000	1,920	900	75	85	120	1,990	2,150	1,020	1,893	947	

※製品重量は、当社のコンクリートを2.5tf/m<sup>3</sup>としての計算質量です。

# 溝蓋 (GSU, DR用) 形状寸法及び製品質量

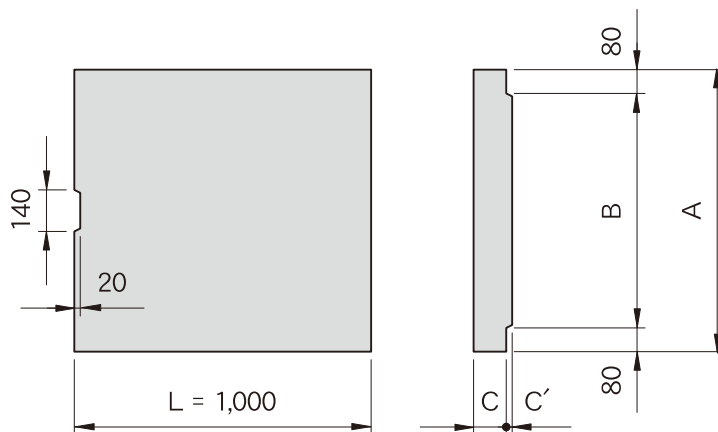

呼び名	T-14用蓋					T-6用蓋				
	寸法 (mm)				質量 (kg/枚)	寸法 (mm)				質量 (kg/枚)
	A	B	C	C'		A	B	C	C'	
30用蓋	—	—	—	—	—	450	290	60	10	74
40用蓋	—	—	—	—	—	550	390	65	10	99
※45用蓋	—	—	—	—	—	570	440	65	10	103
50用蓋	650	490	100	20	186	650	490	70	10	126
60用蓋	750	590	100	20	216	750	590	75	10	155
70用蓋	850	690	110	20	267	850	690	80	10	187
80用蓋	950	790	110	20	300	950	790	80	10	209
90用蓋	1,050	890	120	20	358	1,050	890	85	10	247
100用蓋	1,150	990	120	20	394	1,150	990	85	10	268
120用蓋	1,350	1,190	130	20	497	1,350	1,190	95	10	350
140用蓋	1,550	1,390	140	20	611	1,550	1,390	100	10	422
150用蓋	1,650	1,490	140	20	651	1,650	1,490	100	10	490

※製品質量は当社のコンクリートを2.5tf/m<sup>3</sup>としての計算質量です。

※45用蓋は蓋掛かり幅が65mmとなります。

